

TeeJet® 844-AB

Sprayer Control

Programming and Operating Manual
(3.20)

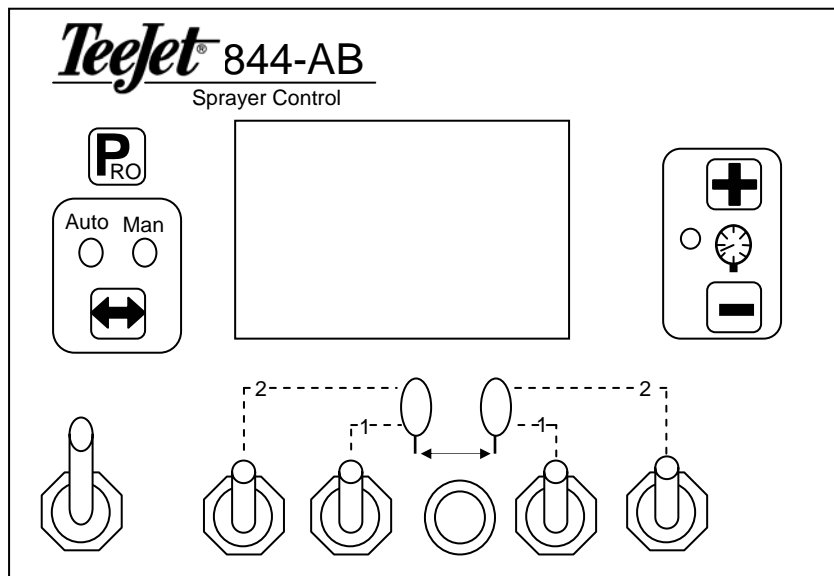

Table Of Contents

TABLE OF CONTENTS	2
PROGRAMMING GUIDELINES	4
IMPORTANT PRELIMINARY INFORMATION	4
POWERING CONSOLE ON/OFF	5
POWER ON.....	5
POWER OFF	6
PROGRAMMING THE SYSTEM SETUP MODE	7
SELECTION OF WORKING UNITS	7
<i>Reset To Defaults</i>	8
SENSOR SELECTION	8
FLOW METER PULSES.....	9
<i>Manual Entry</i>	9
<i>Automatic Calibration</i>	9
PRESSURE TRANSDUCER LOW PRESSURE CALIBRATION (P REF).....	10
PRESSURE TRANSDUCER MAXIMUM RATING (P HI)	11
SPEED SENSOR CALIBRATION.....	12
<i>Proximity/Magnetic Pulses</i>	12
<i>Radar Speed Pulses</i>	13
<i>Manual Calculation</i>	13
SIMULATED GROUND SPEED	14
REFERENCE FLOW RATE PER SECTION	15
<i>Reference Pressure</i>	16
<i>Reference Flow</i>	16
REGULATING VALVE ACTUATING FACTOR	17
PRESSURE REGULATING MODE	18
MINIMUM PRESSURE SETTING	19
DENSITY (LIQUID SPECIFIC GRAVITY).....	19
COMMUNICATIONS	20
SWATH WIDTH PRESETS PROGRAMMING	21
<i>Selecting The Swath Preset</i>	21
PROGRAMMING THE APPLICATION SETUP MODE	23
PRESET SECTION FLOW RATE SELECTION	23
TARGET APPLICATION RATE	24
CALCULATION/WHAT IF? STEP	24
<i>Adjust Pressure</i>	24
<i>Adjust Speed</i>	25
LIQUID DENSITY.....	25
OPERATING INSTRUCTIONS	27
SPRAYER CHECKOUT.....	27
THE SPRAYING OPERATION	29
FEATURES	30
BOOST MODE	30
AREA/VOLUME DISPLAY	31
APPLICATION ALARM	31
NO FLOW ALARM.....	32
AUTO POWER DOWN	32











Programming Guidelines

Make sure that all hardware components are properly installed and tested. Before you start the programming process you should first check if the console and all sensors are working properly. Refer to the plumbing and installation manual supplied with this console.

IMPORTANT PRELIMINARY INFORMATION

Before you begin, we recommend that you review the following Programming Guidelines that control the programming process:

For your convenience, the programming of the 844-AB has been divided into two programming categories; System Setup Mode and User Setup Mode.



- The **System Setup Mode** contains the programming steps that customize the controller to the sprayer or sprayer components. These include calibration steps and parameters that, once programmed, will likely never change.
 - The **User Setup Mode** contains the settings that are most frequently changed: target application rate, and nozzles used.
- * For **ALL** setup modes, if you press and hold the  key for 3 seconds, your inputs will be stored and the computer will exit the setup mode. This action will not be necessary until the last programming step has been completed.
 - * To increase the value of a programmable digit, press the  key. To decrease the value, press the  key. These keys are located directly to the right of the display. For some programming steps, pressing and holding the  or  key will change the programmable value rapidly. Pressing the  or  key once will change the value by one increment.
 - * Pressing the  and  keys simultaneously in some programming steps will set the value to "0" or will start an automatic calibration.
 - * For **ALL** setup modes, pressing the  key will advance you to the next programming step. After the last programming step, the console will return to the first programming step.
 - * **Note: Due to differences in fonts, some letters on the displays shown in this manual are not identical with the corresponding letters on the display of the controller. We tried to match them as close as possible.**

Powering Console On/Off

POWER ON

After all the necessary electrical connections have been made (refer to the Plumbing and Installation manual included with this kit) the console is ready to be powered on. To power the 844-AB on press the  key once. Initially the console will display the software version of the console in the top display and the serial number of the console in the bottom of the display for approximately 5 seconds. This information will be needed when calling for support.

ABL				3.20							
G22						0050					
1	2	3	4	5	6	7	8	9	10	11	12



The display will then advance to the swath width view. This is to inform the operator what the current swath width preset (there are 6 presets) setting is before beginning to spray. If the current swath width selection is correct simply press the  key to advance to the normal operating mode. If the swath width needs to be changed for the application, press the GREEN button to toggle through the current preset swath widths. Once the correct swath width is displayed, press the  key to advance to the normal operating mode.

				/ - / - /							
						11.0					
1	2	3	4	5	6	7	8	9	10	11	12

Note: It is best to not chose the swath width setting until programming of the System Setup Mode has been completed. Selecting the Working Units of the console in the first step of the System Setup Mode will determine if the swath settings are measured in feet or meters.

Simply press the  key to advance to the normal operating mode.

POWER OFF

To manually power the console off, press the  and  keys simultaneously. The console will then count down from 5 to 1 before shutting off. This process allows the console time to save any new information (area and volume counters) to memory.

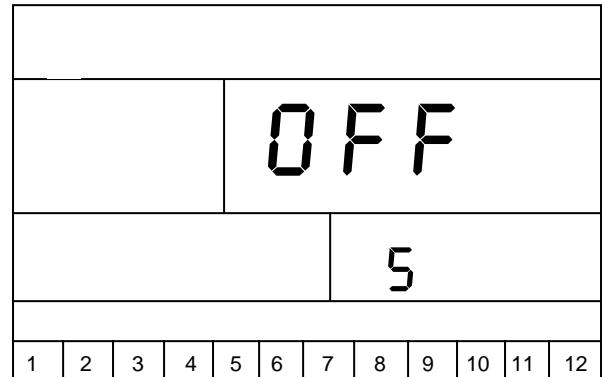

Note: The console also has an Auto Power Down feature. Refer to this in the features section of this manual.

Programming The System Setup Mode

The system setup mode contains the programming steps that customize the controller to the sprayer or sprayer components. These include calibration steps and parameters that, once programmed, will likely never change.

To enter the System Setup Mode, press and hold the **+** and **-** keys simultaneously. While holding the **+** and **-** keys in, press the **P_{RO}** key twice (within 3 seconds), and then release all keys to enter the System Setup Mode. The first programming step should be visible.

SELECTION OF WORKING UNITS

The 844-AB is capable of working in either US or SI (Standard International - metric) units. In this step you select which units you will be using. To determine which units you will need refer to the table below.

Use the **+** and **-** keys to switch from US to SI units. Press the **P_{RO}** key to accept the value and advance to the next program step.

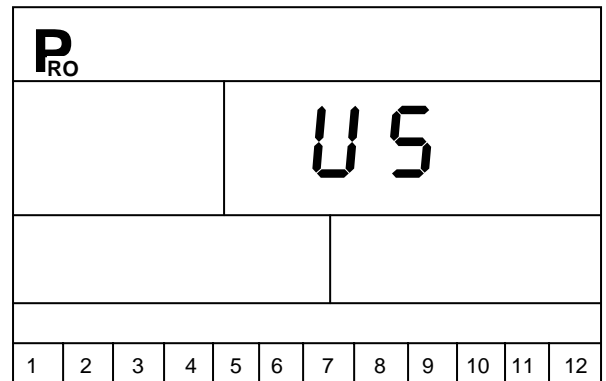

	US	SI
Speed	MPH	Km/H
Flow	GPM	L/min
Area	Acres	Ha
Pressure	PSI	Bar
Volume	Gal	L
Speed Pulses	pulses/300ft	pulses/100m
Tree Spacing	Inch	Cm
Dose Rate	GPA	L/Ha

Reset To Defaults

If you made a change to the units in the first programming step, before advancing to the next step the console will ask if you would like to reset all the program parameters to defaults specified for the units you have chosen. Use the \oplus or \ominus key to select either YES or NO. After you have made your selection, press the P_{RO} key to begin resetting or advance to the next step.

P_{RO}											
RES						YES					
DEF											
1	2	3	4	5	6	7	8	9	10	11	12

Note: If you did not make any changes to the units, this step will be skipped and you will automatically be advanced to Sensor Selection Step.

SENSOR SELECTION

The 844-AB system can be used with either a flow meter, pressure transducer or both. This step tells the computer which sensor you will be using on your sprayer to control the regulation.

The default value is set for a "FLD" based system using a flow meter. If this is what you have installed on your sprayer, then press the P_{RO} key to advance to the next step.

P_{RO}											
						FLO					
1	2	3	4	5	6	7	8	9	10	11	12

If however you have installed a pressure transducer instead, use the \oplus or \ominus key to select "PRS" for a pressure based system. Then press the P_{RO} key to advance to the next step.

Warning

The pressure based regulation may only be used when you are using linear tips. For non-linear tips you should always use flow based regulation. Most tips are linear and may be used with Pressure Based regulation, but ConeJet tips are non-linear.

If both sensors have been installed on the sprayer, this step will determine which sensor will be used by the 844-AB to determine regulation. If "FLD" is selected, the flow meter will be used to control flow and the pressure transducer will be used only to display the actual pressure. If "PRS" is selected, the pressure transducer will be used to control the flow and display the actual pressure. The flow meter signals will be ignored.

The selected regulation mode determines the following programming steps. In the case of flow based regulating, the next step will be the calibration step for the flow sensor (see Flow Meter Pulses”). In the case of pressure based regulation the next step will be the calibration step for the pressure transducer and the flow sensor calibration step will be skipped.

Select the appropriate sensor setting then press the  key to accept the value and advance to the next programming step.



FLOW METER PULSES

During the Flow Meter Pulses step, the  symbol (flow meter turbine) will be flashing at the top of the console display.

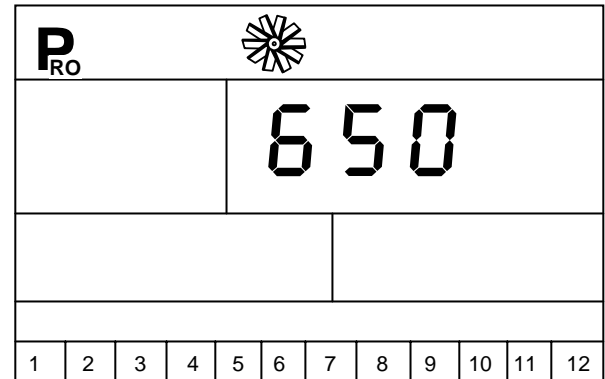
In this step the flow meter calibration number can be entered manually from the factory calibrated flow meter pulse rate tag or an Auto calibration procedure can be activated to determine the flow meter pulses based on a known volume of fluid.





Manual Entry

First locate the factory calibrated flow meter pulse rate tag on the flow meter. If this varies from the default value (it usually does) of the console, use the  or  keys to modify the value.

In some cases, larger flow meters with small calibration numbers will include decimals for greater accuracy. To add a decimal to the 844-AB calibration number, press the  Auto/Man key.

Automatic Calibration

To complete an automatic calibration of the flow meter, press simultaneously on the  and  keys. This will clear the existing value and initiate the calibration procedure.

“CAL” will be displayed in the screen. This indicates that the controller is ready to begin the calibration process.

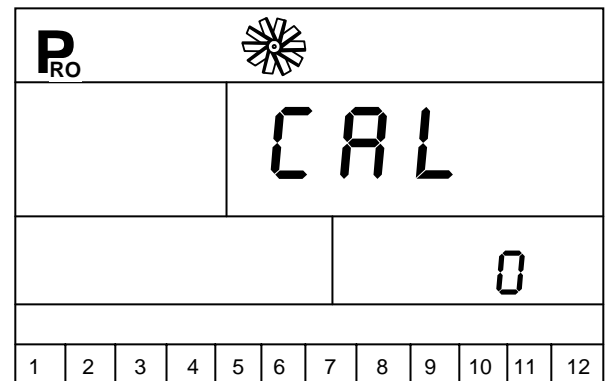

Engage the sprayer pump. Now turn the boom sections on and begin spraying a known volume of fluid (e.g. 100 gallons, 400 liters). As you spray the known amount, the console will count the pulses.

After the known volume has been sprayed out, turn the Master switch off to stop counting pulses.

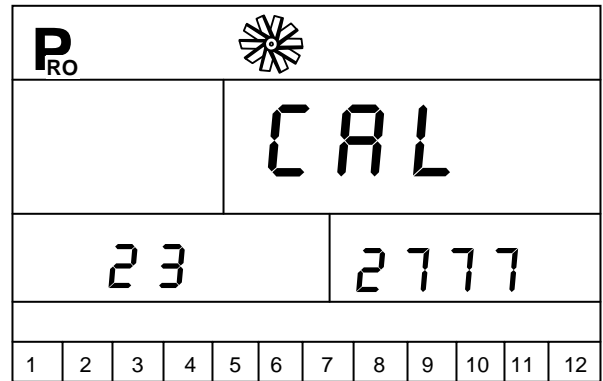

Now press the **P_{RO}** key. The console will now ask what volume was sprayed.

Use the **+** or **-** keys to adjust the value to match the volume sprayed in gallons (liters).

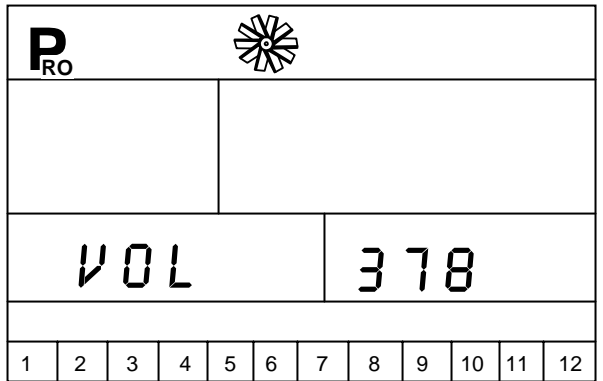

Now press the **P_{RO}** key to return to the programming mode. Your new flow meter calibration number will be displayed. To accept this value press the **P_{RO}** to advance to the next step. If you wish to repeat the calibration procedure refer to the steps above.

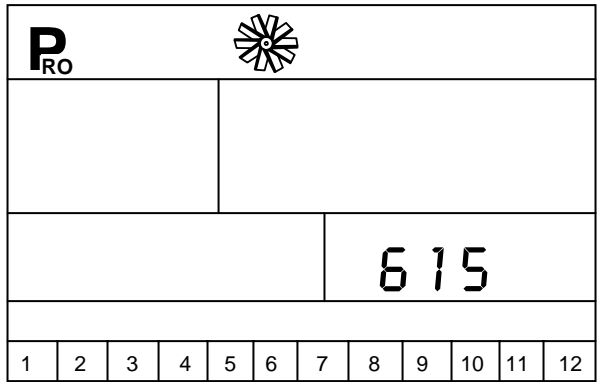

PRESSURE TRANSDUCER LOW PRESSURE CALIBRATION (P REF)

This step is used to calibrate the "0" pressure setting of the pressure transducer installed in your system. The pressure transducer used with the 844-AB is a current type transducer and uses a 4-20 mA reading. 4.0 mA represents 0 pressure.

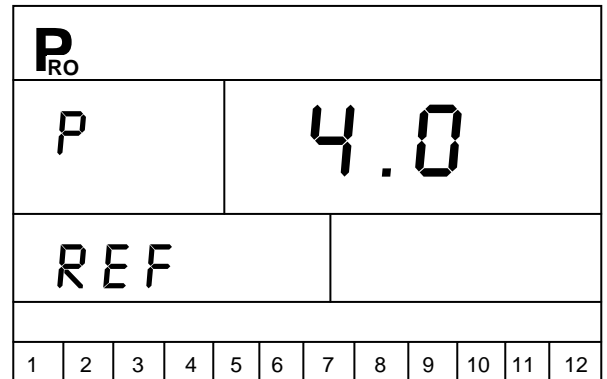

This step uses an auto-calibration feature to calibrate the transducer. Make sure that the sprayer pump is turned off and there is absolutely no pressure in the system. Press and release the \oplus and \ominus keys simultaneously to activate the auto-calibration feature.

You will see the message “ME5” in the lower left of the display and the lower right will count the numbers “0” through “9”.

When the display finishes counting, a number close to 4.0 (+/- 0.2) should be displayed. The low pressure value of the transducer is now calibrated.

Press the P_{RO} key to advance to the next step.

Note: If you do not have a pressure transducer installed in your system, skip this step by pressing the P_{RO} key and leave this value at the default of 4.0.

P_{RO}											
160						3.9					
ME5						9					
1	2	3	4	5	6	7	8	9	10	11	12

P_{RO}											
P						3.9					
REF											
1	2	3	4	5	6	7	8	9	10	11	12

PRESSURE TRANSDUCER MAXIMUM RATING (P HI)

This step is used to set the maximum rating of the pressure transducer in your system. This number can be found stamped on the pressure transducer itself. If your transducer has a maximum rating of 145 psi (10 bar in SI mode) and that number is shown in the display, then advance to the next step by pressing the P_{RO} key. If however, the maximum rating is 363 psi (25 bar in SI mode), use the \oplus and \ominus keys to change the value. Press the P_{RO} key to advance to the next step.

P_{RO}											
P						145					
HI											
1	2	3	4	5	6	7	8	9	10	11	12

Note: If you do not have a pressure transducer installed in your system, skip this step by pressing the P_{RO} key and leave this value at the default of 145 psi (10 bar).

SPEED SENSOR CALIBRATION

Note: During Speed Calibration, the 844-AB will automatically sense whether a Wheel Speed or Radar Speed Sensor is being used.

Proximity/Magnetic Pulses

The speed sensor needs to be calibrated in order to provide the proper speed and area readings. The value for this step is the number of pulses generated by the speed sensor in 300 ft. (100 meters), or by entering the number manually.

Automatic Calibration:

To automatically calibrate the speed sensor, first mark off a distance of exactly 300 ft. (100 meter). Next press the \oplus and \ominus keys simultaneously to clear the contents of the display and to activate the auto calibration mode. When the auto calibration mode has been activated, "CAL" will be displayed at the lower right of the display.

Now start driving toward the start point of the 300 ft. (100 meter) course. As you cross the start point press the \oplus key once to begin the calibration process. Continue across the course and the 844-AB will count the pulses as the sprayer moves. The speed at which you drive over the course is not important. As you cross the end point, press the \oplus key once. The number displayed is your speed calibration number.

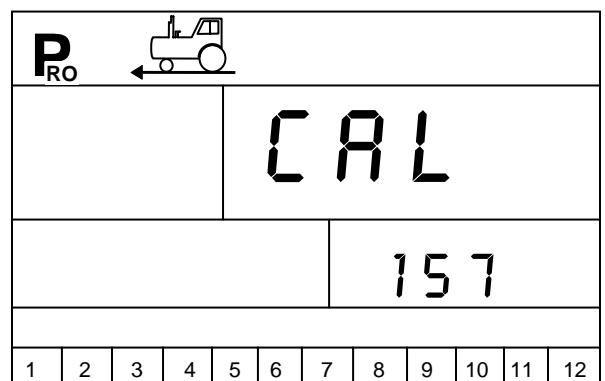
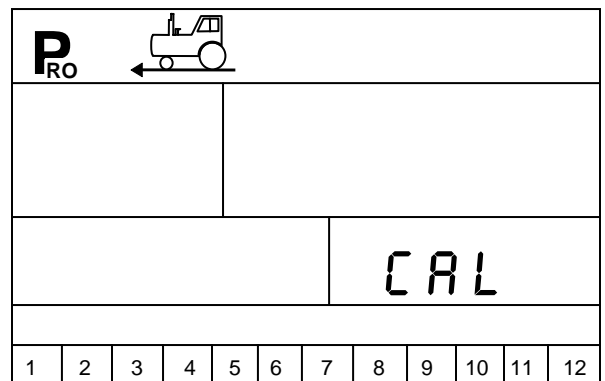
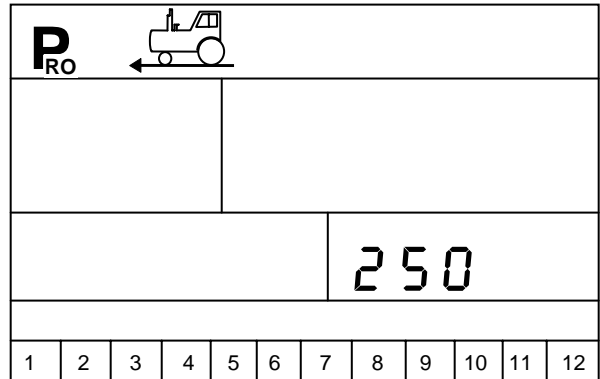

Note: The auto speed calibration process should take place in a field like environment with the sprayer tank $\frac{1}{2}$ full.

Note: It is best to repeat the automatic speed calibration process at least twice and use an average of the speed calibration numbers.

Note: If the auto calibration mode has been activated, no other functions are possible until the console receives speed pulses for calibration. To deactivate the auto calibration mode, press the $\boxed{+}$ key twice.

During the automatic calibration step, the 844-AB automatically senses whether a proximity/magnetic or radar ground speed sensor is installed. If you prefer to enter the speed value manually, refer to the following instructions.

Manual Calculation

To manually calculate the proper value for Wheel Speed Sensor pulses, you need to know the circumference of the wheel to which the sensor is mounted. It can be measured by marking the tire and measuring the distance covered as that mark makes one full revolution. Then use the following formula:

$$\frac{3600 \times \{\# \text{ of magnets on wheel (usually 2)}\}}{\text{Wheel Circumference in inches}} \quad \text{i.e.} \quad \frac{3600 \times 2}{30} = 240$$

$$\frac{10,000 \times \{\# \text{ of magnets on wheel (usually 2)}\}}{\text{Wheel Circumference in cm}} \quad \text{i.e.} \quad \frac{10000 \times 2}{80} = 250$$

The result can be entered as an alternative to using the automatic calibration method. Use the $\boxed{+}$ or $\boxed{-}$ keys to adjust the value. Press the $\boxed{P_{RO}}$ key to validate the value and advance to the next programming step.

Radar Speed Pulses

Automatic Calibration

The automatic calibration of a Radar speed sensor is similar to the automatic calibration of a proximity/magnetic wheel speed sensor. Refer to the directions above. When the console has determined that a Radar Speed Sensor is being used, "RAD" will be displayed in the lower left of the console display.

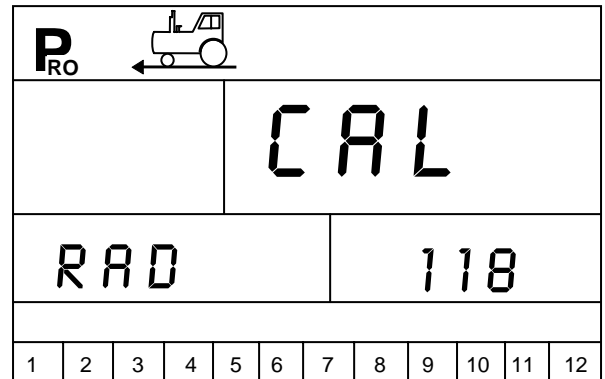





Manual Calculation

It is not possible to manually calculate the calibration value of a radar. However, the value can be entered manually if the value is known from a previous calibration. To manually enter the radar calibration value, first press the $\boxed{\leftrightarrow}$ Auto/Man key to put the control console into radar mode. When the control console is in the manual radar calibration mode, "RAD" will be displayed in the lower left of the console display. Now use the $\boxed{+}$ or $\boxed{-}$ keys to adjust the value. When the correct value has been entered, press the $\boxed{P_{RO}}$ key to validate this value and advance to the next step.

SIMULATED GROUND SPEED



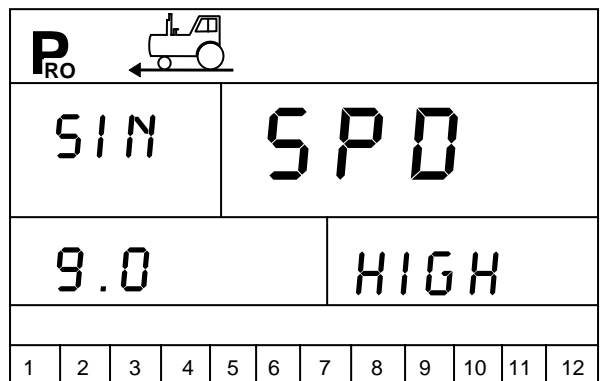
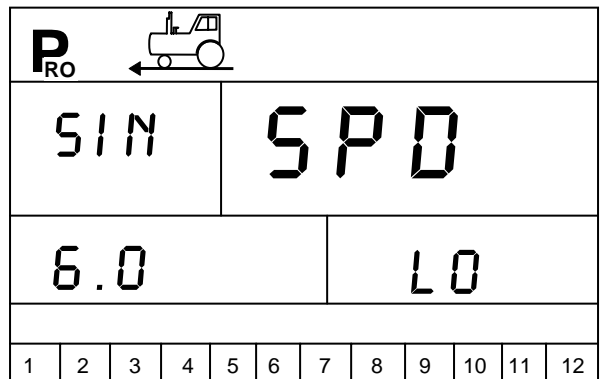

Simulated ground speed allows you to check out the functions and operations of the console and of the sprayer, spraying water, without actually moving the sprayer. This can and should be done prior to any spraying activity.

The 844-AB has a low and high simulated ground speed. This allows you to switch between the two to simulate a speed change to ensure the console is regulating properly during the Sprayer Checkout.

To set the simulated speeds, first note whether the low or the high simulated speed is displayed in the lower right portion of the display. The change from low to high and back press the  Auto/Man key. Use the  and  keys to adjust the values. When both values have been set, press the  key to advance to the next step.



When you exit the System Setup Mode you will notice that the speed display shows the simulated speed you entered. The simulated speed will remain in the normal operating mode display until the console receives actual speed pulses.

While in the normal operating mode with the master switch on, press the  and  keys for low simulated speed; press the  and  keys for high simulated speed.

Note: Once the sprayer begins moving and the 844-AB receives actual speed pulses, the simulated speed feature is deactivated. If you are using a Radar Speed Sensor, disconnect the Radar connection from the main console. Because of the sensitivity of this speed sensor, any movement can disable simulated speed.

REFERENCE FLOW RATE PER SECTION

The 844-AB console must know what the flow rate is for each section of the sprayer so that it can make the necessary adjustments when boom sections are shut off. The console makes an assumption that the left and right boom sections are symmetrical; therefore it assumes that the flow rate for the lower left section (L 1) is identical to the flow rate for the lower right section (R 1). The flow rate entered for section 1 (-1-) will be a reference flow for either L 1 or R 1.

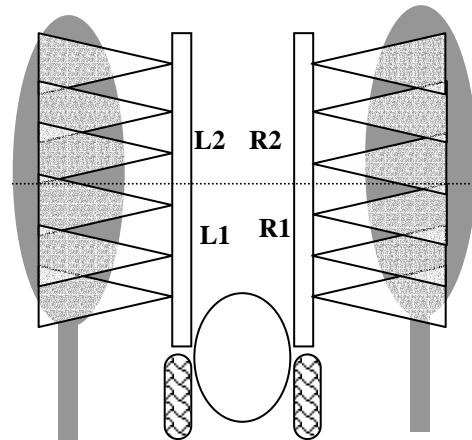

Up to 12 preset flow configurations can be entered into the 844-AB. These presets are represented by the numbers 1-12 at the bottom of the display. The arrow symbol indicates which preset you are currently programming during this step.

First you will select which preset flow configuration you want to program. Use the \oplus or \ominus key to toggle through the 12 presets. Pressing the \leftrightarrow Auto/Man key will advance you into the selected preset.

Pressing the P_{RO} key will advance you to the next program step in the System Setup Mode. It is not necessary to program all 12 presets unless you intend to use them. Simply program the number of presets that you will need, then press the P_{RO} key to exit this step and move on in the System Setup Mode.

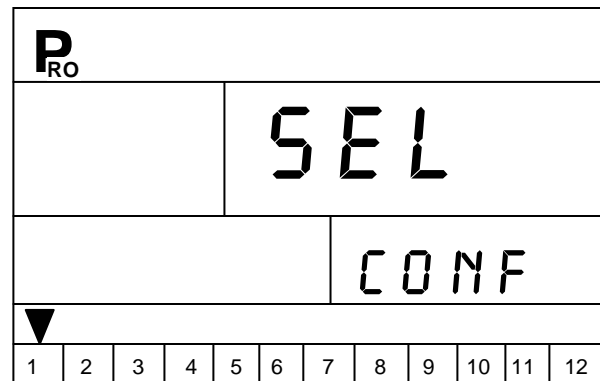

Reference Pressure

Before entering the reference flow, you must first determine the pressure at which you will be referencing the flow.

Use the \oplus and \ominus keys to adjust the value to the pressure (psi or bar) that you will use to reference the flow. The pressure you select to reference the flow is not critical. Any pressure can be used. Select a pressure that is close to your normal operating pressure or select any pressure from the flow rate chart for the nozzles you are using.

After you have selected the reference pressure to be used, press the \leftrightarrow Auto/Man key to advance to the reference flow for preset #1.

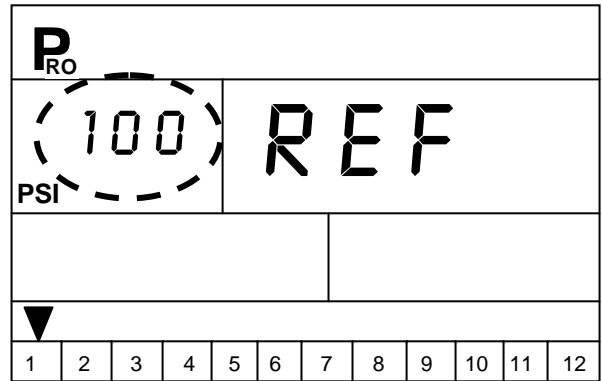





Reference Flow

First add the flow rates at the referenced pressure from all the nozzles on section 1, left or right (should be the same). Now enter this total flow rate in GPM (l/min) for section 1. Use the \oplus or \ominus keys to adjust the value.

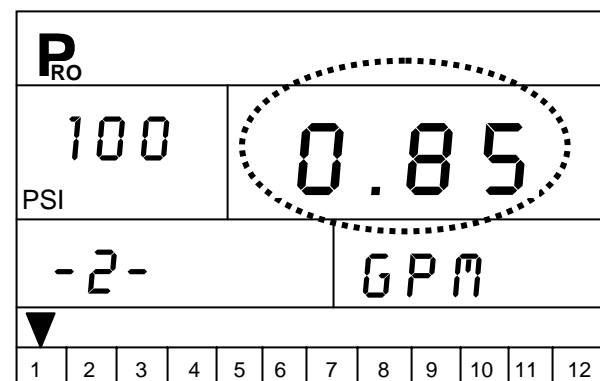
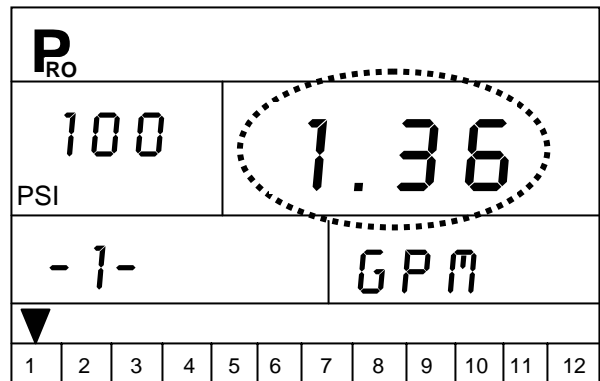
When you have completed the flow entry for section 1, press the \leftrightarrow Auto/Man key to switch to section 2.

Now add the flow rates at the referenced pressure from all the nozzles on section 2, left or right (should be the same). Enter this total flow rate in GPM (l/min) for section 2. Use the \oplus or \ominus keys to adjust the value.



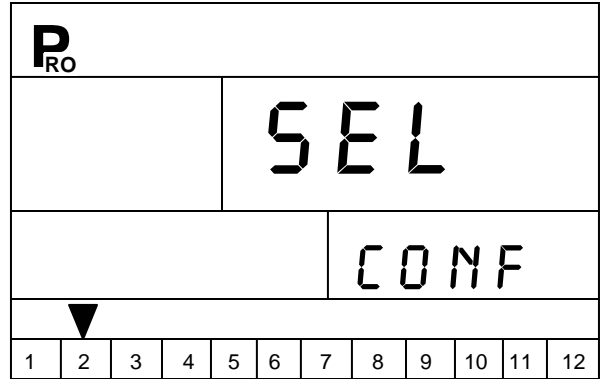

Press the  Auto/Man key to advance to the Select Configuration display. Use the  or  key to advance to another preset flow configuration if necessary. Follow the steps above for programming the reference pressure and reference flow for presets 2-12.



After you have completed programming the reference pressure and reference flow for all the presets that you will be using, press the  key to advance to the next programming step.

REGULATING VALVE ACTUATING FACTOR

This step allows you to adjust the speed of the pressure regulating valve.

Operating conditions may necessitate a higher or lower response speed for the regulating valve. To change the response time number, simply use the  or  keys to increase or decrease the number. Any number between 0.0 and 9.9 may be selected. **0 = Slow 9 = Fast**

The first digit sets the speed for coarse adjustments (when relatively far from the target rate). The second digit sets the speed for the fine adjustment (when relatively close to the target rate).

If your regulating valve is plumbed in a bypass line, the valve speed number of 9.5 works very well in most applications.

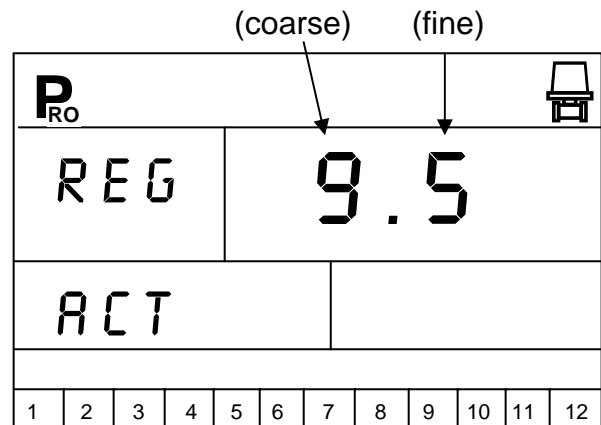

If your regulating valve is plumbed in the throttling position (supply line), start with a valve speed number of 3.0 and adjust the number according to your application requirements. Adjusting agitation volumes can often assist the regulating valve operation.

To accept your Regulating Valve Actuating Factor and advance to the next step, press the  key.



Note: This speed value can be adjusted to optimize system performance. If you notice that the valve seems to “search” for the programmed application rate by cycling the pressure up and down continuously, reduce the number until the “searching” is minimized or eliminated. Conversely, a higher number will increase the valve response speed and speed up the rate of adjustment.



PRESSURE REGULATING MODE

This step tells the 844-AB where the regulating valve has been plumbed. Once set correctly, this value should not change unless the regulating valve is physically moved to a new point in the plumbing. For more information about plumbing refer to the Plumbing and Installation manual supplied with this kit.



The default value “BYP” indicates that the pressure regulating valve is plumbed in a bypass line. If this is correct press the  key to accept the value and advance to the next step.

P RO												
		BYP										
1	2	3	4	5	6	7	8	9	10	11	12	

Note: When programmed in the bypass mode, with the controller in “MAN” mode, the pressure regulating valve should close when the  key is pressed and open when the  key is pressed.

If you have plumbed the pressure regulating valve in a supply line to the booms, this is considered a throttling position. If you have located your regulating valve in this position, use the  or  key to change the value to “THR” (throttling mode). By doing this, you have reversed the polarity that the console uses to control the regulating valve.

P RO												
		THR										
1	2	3	4	5	6	7	8	9	10	11	12	

Note: When programmed in the throttling mode with the controller in “MAN” mode, the valve should open when the  key is pressed and close when the  is pressed.

Press the  key to advance to the next step.

MINIMUM PRESSURE SETTING

This programming step allows you to set the minimum pressure that the sprayer control will regulate to. Sometimes when the sprayer slows down, the control system will regulate the pressure so low that it falls below the manufacturer's recommended pressure for the spray tip or reduces system flow to the point where the flow meter will stall.

To avoid these situations, the 844-AB can be programmed to not regulate below the pressure set in this step. If this step is set for the default of 10 PSI (0.7 bar), the pressure will not go below 10 PSI (0.7 bar) while spraying in automatic mode.

Use the \oplus or \ominus keys to adjust this value.

Press the P_{RO} key to advance to the next programming step.

P_{RO}												
10												
PSI												
MIN						PRS						
1	2	3	4	5	6	7	8	9	10	11	12	

DENSITY (LIQUID SPECIFIC GRAVITY)

The default value of "1.00" corresponds with the specific gravity of water and is correct for most pesticide applications. Occasionally some spray solutions, such as fertilizer, have different densities. If you are using such a material, a new value should replace the default value. The chart at the right can help you determine the density of other solutions.

To change the default value to your new value, use the \oplus or \ominus keys to change the value in the display. Pressing the \oplus and \ominus keys simultaneously will clear the value to zero. To accept the value and advance to the next programming step, press the P_{RO} key.



$\text{P}_{\text{RO}} \text{D}$											
						1.28					
1	2	3	4	5	6	7	8	9	10	11	12

Weight of Solution Per Gallon	Weight of Solution Per Liter	Specific Gravity
7.0 lbs.	0.84 Kg	0.84
8.0 lbs.	0.96 Kg	0.96
8.34 lbs. – Water	1.00 Kg	1.00
10.0	1.20 Kg	1.20
10.65 lbs. – 28%N	1.28 Kg	1.28
10.85 lbs. – 30%N	1.30 Kg	1.30
11.0 lbs.	1.32 Kg	1.32
12.0 lbs.	1.44 Kg	1.44
14.0 lbs.	1.68 Kg	1.68

If the solution you are using can not be found on the chart above, the Specific Gravity can be calculated as follows:

$$\text{Specific Gravity} = \frac{\text{Weight of Solution}}{\text{Weight of Water}}$$



Note:
Water weighs 8.34
lbs/gal or 1 Kg/L

Note: To activate this specific gravity number, while in the Application Setup Mode, press the  Auto/Man key so the “D” is displayed at the top of the screen. When the “D” is displayed, all calculations performed will use the specific gravity programmed in this step. To remove the “D” press the  Auto/Man key. When the “D” is not displayed all calculations performed will use the specific gravity of water (1.00) regardless of whether another density is programmed into this step or not. Refer to the Application Setup Mode in this manual for more information.

COMMUNICATIONS

If your 844-AB has been upgraded to be communications compatible, this step lets you select what type of communication you will be using. The choices available are the default of “NO COM” (no communications), “CNT PRT” (Contractor printing), “USR PRT” (User printing), “GPS” (Global Positioning System communication capability), “LOG” (Downloading to a PC on the go capability), or “PC” (PC link – not used).

P <small>RO</small>											
NO						COM					
1	2	3	4	5	6	7	8	9	10	11	12

If your 844-AB has not been upgraded with the communication package, no change is necessary from the default. If, however, your 844-AB has been upgraded with the communications package, use the  and  keys to select the type of communication you will be using.

After selecting the communication you will be using, press the  key to advance to the next step. This advances you to the beginning of the System Setup Mode.

Now press and hold the  key for three seconds to exit the program mode and save the programming information to the computer’s memory.

Note: For your protection, the 844-AB console will not automatically power down while in the System Setup Mode. You must exit properly as described above to enable the console’s auto power down feature.

Note: Cutting the power to the controller while in the System Setup Mode will not save any changes into the computers memory.

Swath Width Presets Programming

The 844-AB can be pre-programmed with up to 6 swath width or tree row settings. This allows the operator to easily change from one swath to another, even on-the-go. This is essential when spraying orchards that have swath widths that vary across the orchard.

To enter the Swath Width Presets Mode, you must start from the normal operating mode, then press and hold the GREEN button for 3 seconds. You will then see the swath width setting screen for preset number 1. The swath width is shown in the lower right display. The swath is indicated in feet for US units and in meters for SI units.

Use the \oplus and \ominus keys to adjust the value for the first swath preset. Press the GREEN button or the P key to advance to the next swath preset. Use the \oplus or \ominus keys to adjust the swath value. Continue this process through the six possible presets. If you do not need all six presets, program values for only the number of presets you will need. Set all others to 0. Any values set to 0 will not be available for selection later when you choose which preset you want to use. After you have programmed all six swath presets, press the GREEN button or the P key to advance back to the normal operating mode.

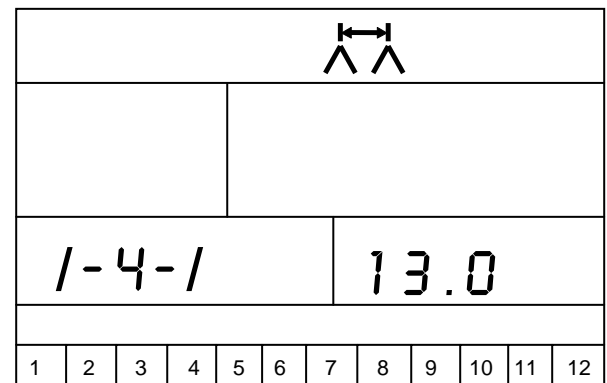
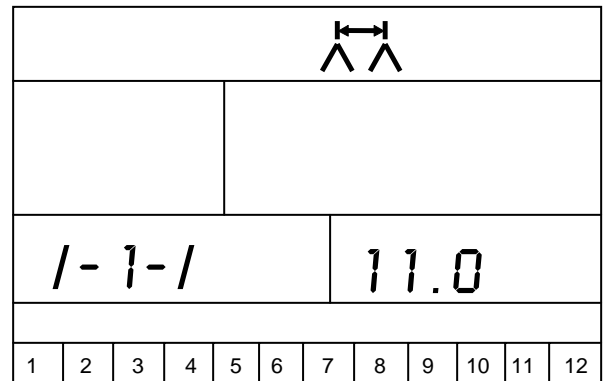

Selecting The Swath Preset

After you have programmed all the possible swath widths that you might have, you may select the swath width to use by pressing the GREEN button from the normal operating mode. The display will show you which swath preset the console is currently using. If this preset is the correct one, press the P key to go back to the normal operating mode.

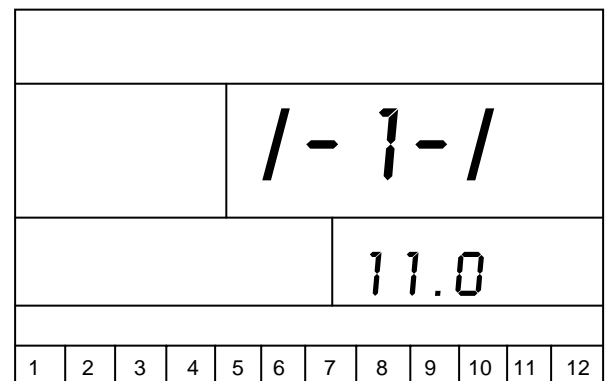

If you wish to select a different swath preset, pressing the GREEN button again will advance you to the next swath selection. Continue to press the GREEN button until you reach the swath preset you wish to choose. When the desired swath is displayed, press the  key to select the swath and advance to the normal operating mode.

						1-2-1					
						12.0					
1	2	3	4	5	6	7	8	9	10	11	12

Note: When toggling through the swath width selections, you will only be able to view those presets that have values programmed. Therefore if presets 5 and 6 were set to 0, you will only be able to select from presets 1-4.

Programming The Application Setup Mode

The Application Setup Mode contains the programming steps that are most frequently changed (target application rate and nozzles used). Spraying Systems Co. has added this separate setup mode to speed the programming process when minor changes are made in the spraying operation (i.e. changing orchards, switching nozzles, changing crops, etc.). The operator can avoid the unnecessary programming steps.

To enter the Application Setup Mode, from the normal operating mode, press the **P_{RO}** key twice (within 3 seconds). Pressing the **P_{RO}** key once will display “*PRO USER*” indicating that the console is about to enter the Application Mode. If the **P_{RO}** key is pressed once inadvertently, the screen will display “*PRO USER*” for three seconds and then return to the normal operating mode. Pressing the **P_{RO}** key a second time in 3 seconds puts the control console into the Application Setup Mode.

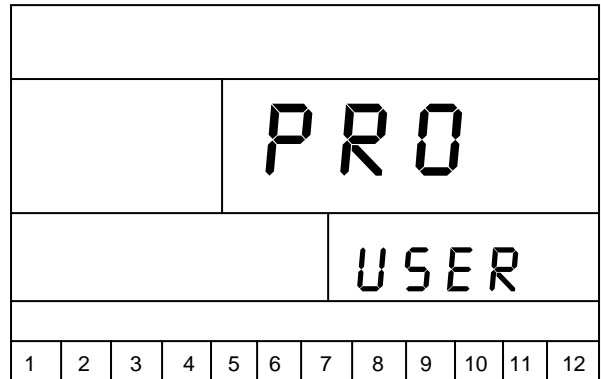

PRESET SECTION FLOW RATE SELECTION

The ▼ symbol will flash at the bottom of the screen. The numbers 1-12 at the bottom of the screen represent the preset reference flow rate configurations that were programmed in the System Setup Mode. Use the **+** and **-** keys to toggle the ▼ through these presets and select the one you will be using for this application.

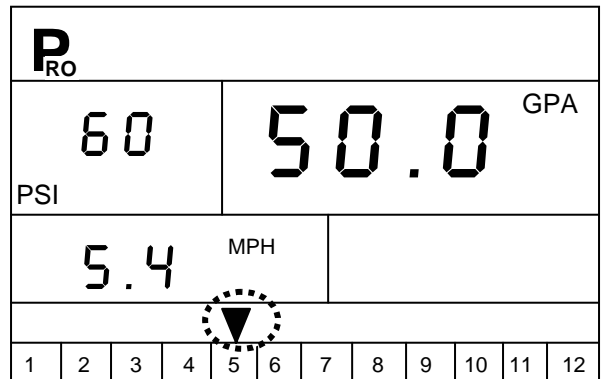

After you have positioned the ▼ over the preset number you will be using, press the **P_{RO}** key to advance to the next step.

TARGET APPLICATION RATE

While in the Target application Rate step, the application rate units (i.e. GPA, L/Ha) will be flashing. Your target application rate should be entered in this step. Press the \oplus or \ominus keys to adjust the value. Pressing the \oplus and \ominus keys simultaneously will clear the value to zero.

When the desired application rate has been entered, press the P_{RO} key to accept the value and advance to the next step.

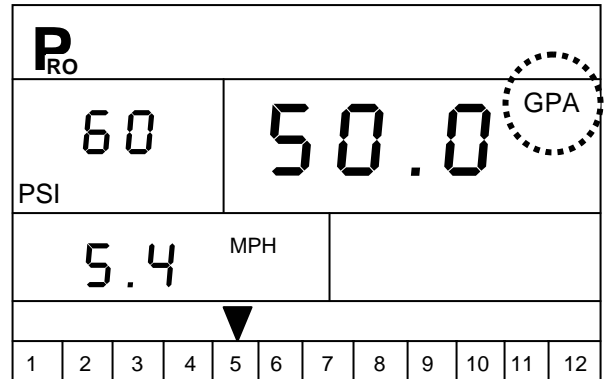

CALCULATION/WHAT IF? STEP

This programming step is a diagnostic tool only and has no effect on the operation of the TeeJet 844-AB Sprayer Control. It allows the user to adjust the indicated pressure to see what effect it would have on the operating speed, or the user can adjust the speed to see what pressure would need to be used to maintain the target application rate. This step should help determine if the correct nozzle configuration was chosen for the application.

While in the calculation step, either the pressure or speed units will be flashing.

Adjust Pressure

If you know approximately what you would like your operating pressure to be, use the \oplus or \ominus keys to adjust this value. The 844-AB will immediately determine what the operating speed would need to be to achieve the target application rate at this pressure. If the speed indicated is too high, a set of smaller nozzles is needed. If the speed indicated is too low, a set of larger nozzles is needed.

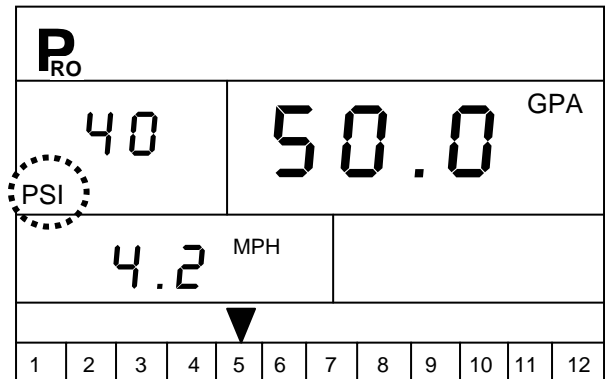

Adjust Speed

If you wish to adjust the speed, press the **P** key once so that the speed units begin to flash. Use the **+** or **-** keys to adjust the indicated speed to a value that you know you will be traveling at. The 844-AB will immediately calculate what the pressure would need to be to maintain the target application rate at this speed. If the pressure is too high, you will need a set of larger nozzles or will have to slow down. If the pressure is too low, you will need a set of smaller nozzles or will have to speed up.

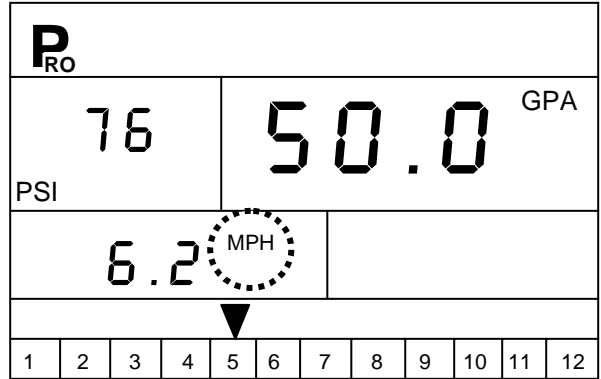

LIQUID DENSITY

To activate the Liquid Density press the **↔** Auto/Man key. The **D** symbol will appear at the top of the screen and the display will show the Liquid Density that is currently programmed into the console. To change the density use the **+** or **-** keys. If the current density is correct or after you have made your changes press the **P** key to advance back to the calculation step. The calculations are now using the programmed Specific Gravity (Density). To go back to the calculation based on spraying water, press the **↔** Auto/Man key.

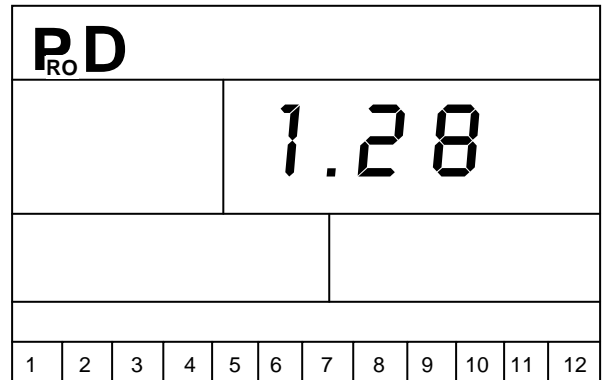

Note: If you will be spraying a liquid with a density other than water and you have programmed that density into the Specific Gravity (Density) Step in the System Setup Mode, you must select the **D** symbol in the Application Setup Mode to activate this alternate density. Press the  Auto/Man key while in the Application Setup Mode to activate the alternate density. A **D** will be at the top of the display when the alternate density is activated. This must be displayed so that all calculations will use the alternate density in the normal spraying mode.

If you do not see the **D** symbol at the top of the display this means that you have not selected a different density and that all calculations will be based on water (1.00).

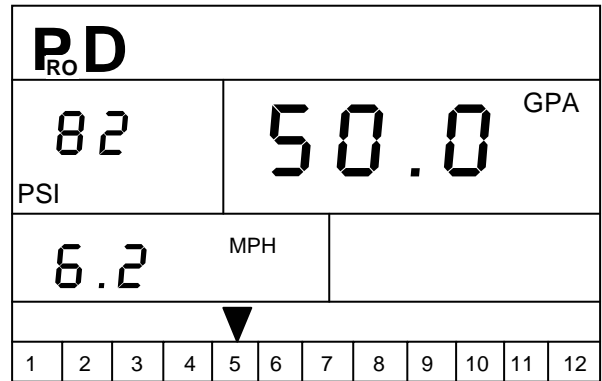

After performing the calculations, you can advance to the beginning of the Application Setup Mode to make changes by pressing the  key. If no changes are necessary, you have completed the Application Setup Mode of the TeeJet 844-AB Sprayer Control.

Now press and hold the  key for three seconds, and the Application Setup Mode will be stored in the computer's memory.

Note: For your protection, the 844-AB console will not automatically power down while in the Application Setup Mode. You must exit properly as described above to enable the console's auto power down feature.

Note: Cutting the power to the controller while in the Application Setup Mode will not save any changes into the computers memory.

Operating Instructions







SPRAYER CHECKOUT

Before spraying check all connections related to the Sprayer Control Assembly. Particular attention should be given to the sensors to be sure the console receives good uninterrupted signals. Be sure connections are made and the sensors are properly secured.





Very Important: Whenever you are working around a sprayer or farm chemicals, be sure to wear protective clothing and eyewear.

Partially fill the sprayer tank with water to flush the system and to make a visual check of the spray tips to be sure all tips are delivering a good spray pattern.

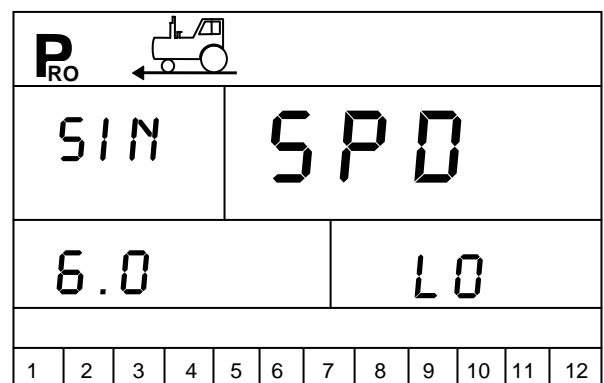



Follow these steps, in sequence, being sure the Master Boom Switch is in the "OFF" position:

- ◆ Be sure the tank shut-off valve is open.
- ◆ Start the engine, engage pump and set the rpm to that which will be used when spraying.
- ◆ Turn the computer on by pressing the  key.
- ◆ Ensure that the preset reference flow number matches the set of tips you are using.
- ◆ Ensure that the console recognizes the simulated speed. If the simulated speed has been disabled due to movement of the sprayer simply the  and  to activate the high simulated speed or the  and  keys to activate the low simulated speed.
- ◆ Turn "ON" the toggle switches for each of the spray boom sections on your sprayer.
- ◆ Press the  Auto/Man key so that the red LED light indicates "MAN" mode.
- ◆ Now, toggle the Master boom switch to "ON".



- ◆ Adjust the pressure with the  and  keys. The pressure should increase when you press the  key and decrease when you press the  key.

At this point, the sprayer will be activated and spray tip performance can be visually checked.

- ◆ Now press the  Auto/Man key so that the red LED light indicates “Auto” mode. The control console should regulate to the target application rate for the simulated speed indicated.
- ◆ Press the  and  keys simultaneously (while spraying) to switch the console to “high” simulated speed. The control console should increase the pressure and regulate to the target application rate for the new simulated speed.
- ◆ Press the  and  keys simultaneously (while spraying) to switch the console to “low” simulated speed. The control console should decrease the pressure and regulate to the target application rate for the new simulated speed.



To stop spraying, toggle the Master boom switch to “OFF”.

The above steps provide a quick way to check out your sprayer and computerized control system.

However, it is recommended that you calibrate your entire sprayer to prepare the machine for operation and to diagnose spray tip wear. Worn tips can contribute to costly chemical waste and inaccurate spraying regardless of your use of a sprayer control. Calibration is important and necessary to obtain the benefits associated with a computerized sprayer control.

THE SPRAYING OPERATION

You have filled the sprayer tank and have thoroughly mixed the chemical(s). Your application rate has been determined as well as the nozzles you will be using, with the sprayer data programmed into the computer.

- ◆ Turn the control console on by pressing the  key.
- ◆ Toggle the individual boom switches to the “ON” position, for each of the booms on your sprayer.
- ◆ The  Auto/Man key should be switched to “AUTO”.
- ◆ In the Auto mode, when the Master boom switch is “OFF”, the target application rate as well as the target symbol will be displayed in the console display. When the Master boom switch is “ON”, the actual rate will be displayed and the target symbol will no longer appear.
- ◆ While spraying with the Master boom switch “ON”, the display will always display the actual application rate, vehicle speed, application area covered/total volume applied and pressure (only if a pressure transducer has been installed).
- ◆ As you enter the field to the point where you will begin spraying, turn the Master boom switch to the “ON” position. This will activate the spraying operation. Maintain your usual vehicle speed for spraying. Moderate changes in vehicle speed will not affect your application rate, because such changes are compensated by automatic pressure increases or decrease by the controller.

If for any reason you need to stop, turn the Master boom switch to “OFF”.

Alarm warnings can occur momentarily while the pressure regulating valve is searching for a new setting (i.e. after the close of a boom section or other change in normal operation). However, if the alarm stays on for a longer time, the valve may have reached its limit and your system will be unable to regulate flow beyond the limit.

Features

BOOST MODE

There may be instances where “on-the-go” increased or decreased chemical application may be required in certain areas of your orchard. In situations like this, the \oplus and \ominus keys will allow you to easily make the necessary adjustments. The boost mode can be activated while spraying in Auto mode by pressing either the \oplus or \ominus key once. With each subsequent pressing of the \oplus key the application rate will be increased by 10%. Each subsequent pressing of the \ominus key will reduce the application rate by 10%.

If the \oplus or \ominus key is pressed once inadvertently during operation, a delay of three seconds will deactivate the boost mode. Succeeding presses will change the target rate as explained above to a maximum of +/- 90% of the target.

Example: If increasing the application rate by 10%, press the \oplus key once to activate the boost mode, and a second time to make the 10% increase. If decreasing the application rate by 10%, repeat the above procedure using the \ominus key.

The application rate changes are monitored in the display, as you make them. The display will show UP 10, UP 20, dn 20, dn 30, etc. This will be displayed for approximately three seconds before the display returns to reading actual application rates. When making application rate changes, it is not necessary to set the Auto/Man to “MAN” mode.

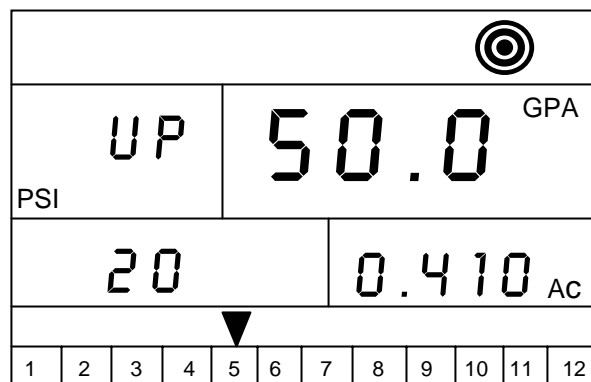

To return the application rate to the original target rate, you may use the \oplus or \ominus keys individually to step in 10% increments, or press the \oplus and \ominus keys simultaneously to return to the programmed target application rate in one step.

Note: While in the boost mode, the target symbol will flash at the top of the console display, to remind the operator they are not spraying at the target application rate.

AREA/VOLUME DISPLAY

The 844-AB Sprayer Control will count application area and measure the total volume applied while the master boom switch is in the “ON” position. The area counter will measure treated acres (hectares) and is dependent on the value programmed for swath width. The volume measure is dependent on flow meter pulses and is available on flow based models only.

The lower right of the display window will alternately show the treated area sprayed and the total volume applied (gallons or liters) since the last clearing of the area counter/volume measure.

To clear the area counter/volume measure, press and hold the \oplus and \ominus keys simultaneously for three seconds. The area/volume measure can only be cleared from the normal operating mode, with the master boom switch in the off position.

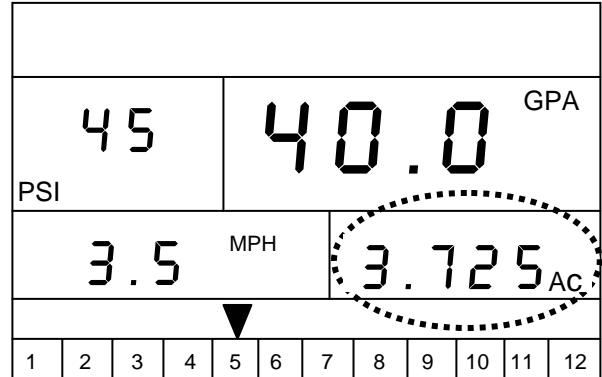

Note: The area memory counter/volume measure only works when the Master boom switch is turned “ON”.

Note: If you are using a pressure based controller, the volume feature is disabled. The total area will then be displayed at all times.

APPLICATION ALARM

If the 844-AB senses a continuous discrepancy of 10% or more between the Target Application Rate and the Actual Application Rate, the application rate units (GPA, L/Ha) will flash in the display window. This alarms the operator to a problem with the sprayer plumbing, operation or programming.

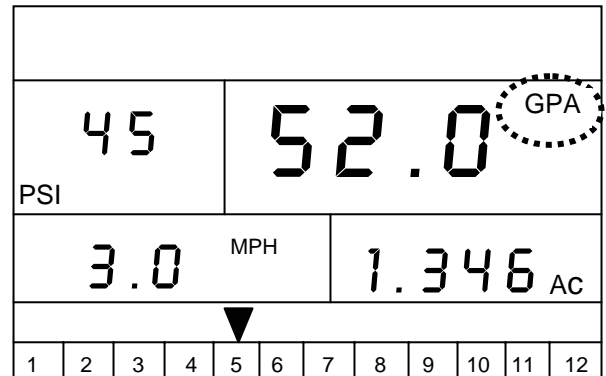

No Flow Alarm

If the 844-AB stops receiving pulses from the flow meter the turbine symbol will flash at the top of the display. This alarm indicates that the flow meter has stalled and alerts the operator that there is a problem with the flow meter or elsewhere in the system.

This alarm will occur only when the Master boom switch and at least one boom toggle switch is "ON".

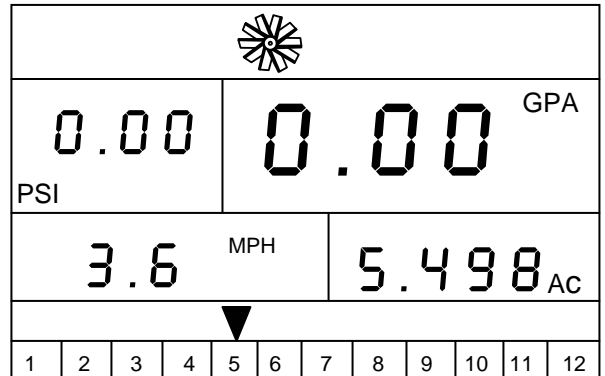

AUTO POWER DOWN

The 844-AB console is designed to power itself off after 10 minutes of no inputs. This feature keeps the console from draining the battery on the sprayer if the operator inadvertently leaves the console powered on for an extended period. This will only occur when the Master boom switch is turned OFF and the console is not receiving inputs from any of the sensors (the sprayer is inactive).

To manually power the console off, refer to the Powering Console On/Off section of this manual.



Note: The Auto Power Down feature is disabled any time the console is in any program mode. The console will not power down while in a program mode. You must exit the program mode properly first before powering down to ensure all the information has been saved to the computer's memory.

PRINTING

Optional printers are available for printing a spraying report directly from the 844-AB. The printing feature is only available on 844-AB consoles that have been upgraded with the communications package. The optional printer and 844-AB communications package are available through your TeeJet supplier.

The printout that you get from the 844-AB contains memory information that the 844-AB collects.

To set the 844-AB for printing, advance to the Communications step in the System Setup Mode and select either "USER PRT" or "CN PRT" depending on which report you want. This must only be done once. Now you can exit the program mode by pressing the  key for three seconds.

Next, connect the printer to the 844-AB and make sure that the LED's to the printer are lit indicating that the printer has power. Ensure that the console is in the normal operating mode with the Master switch "OFF". Press on the  key for three seconds to begin printing. To reset these values to zero, press the  and  keys simultaneously for three seconds.

Note: Printing is only available to 844-AB consoles that have been upgraded with the communications package. To determine if your console is communication ready, look at the left end plate of the console. A communication ready console will have an RS232 nine pin connector attached to the left end plate. If the end plate has no connection, then your console has not been upgraded with the communication package.